

ACTUAL PANEL MAY DIFFER FROM THE PANEL SHOWN

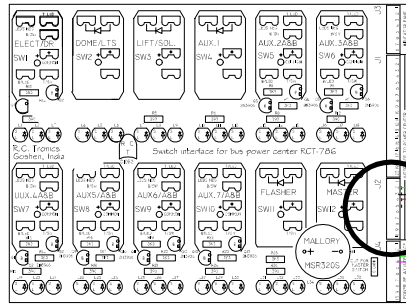
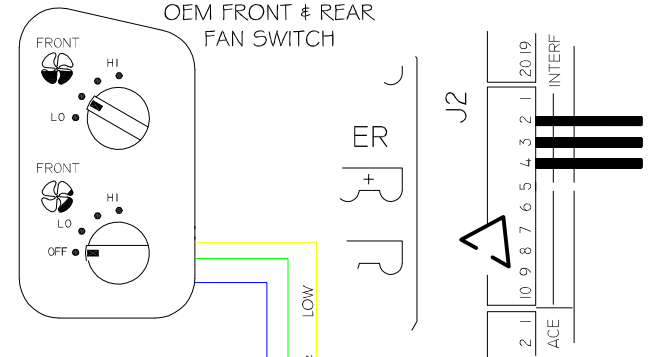
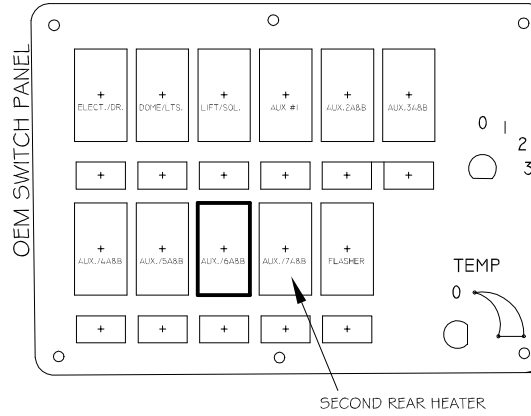
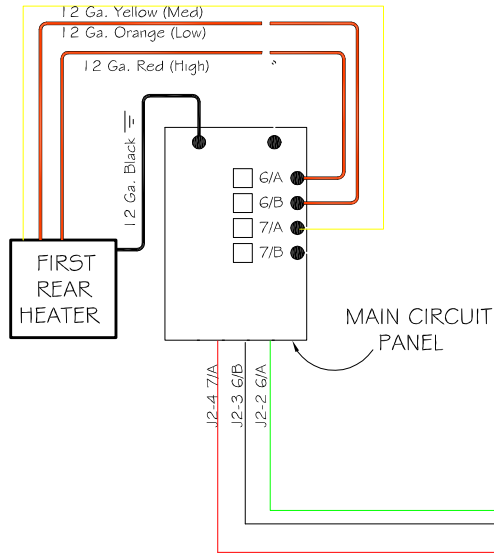

OEM CIRCUIT BOARD BELOW SWITCH PANEL

16 Ga. Green

16 Ga. Purple

**STARCRAFT AUTOMOTIVE INC.**  
BUS & MOBILITY DIVISION

TOLERANCE UNLESS OTHERWISE SPECIFIED  
± .00 ± .030  
± .000 ± .015  
± .0000 ± .005

DATE: 10/26/09  
DFTSN: BG  
CHKR:  
APRVD:

TITLE: FORD HEATER CIRCUIT  
2010 3 sp Heater  
DWG. No. 510091  
SCALE  
DISK No. SHEET 1 OF 1

REV. LET.	DESCRIPTION OF CHANGE	BY	CHK	DATE	ECN No.

THIS DRAWING AND THE INFORMATION THEREON ARE THE EXCLUSIVE PROPERTY OF THE STARCRAFT CORPORATION. IT SHALL NOT BE COPIED OR DUPLICATED IN ANY MANNER, NOR SHALL IT BE SUBMITTED TO OUTSIDE PARTIES FOR EXAMINATION WITHOUT OUR WRITTEN CONSENT. IT IS LOANED FOR USE WITH REFERENCE TO WORK UNDER CONTRACT WITH, OR PROPOSALS SUBMITTED TO THE STARCRAFT CORPORATION.